

轴承座

d1 20-60mm-F507-WA-L

参数信息:

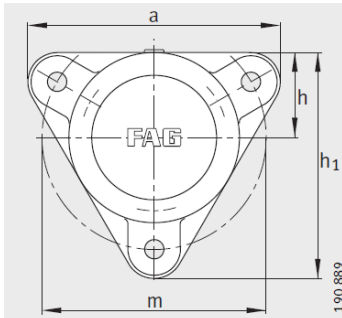

F505、F506、F508

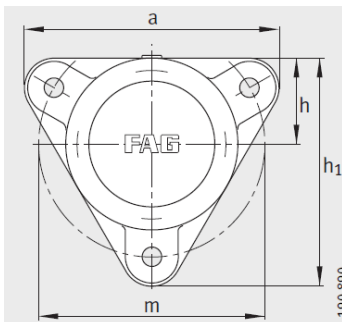

F507、F509 到 F513

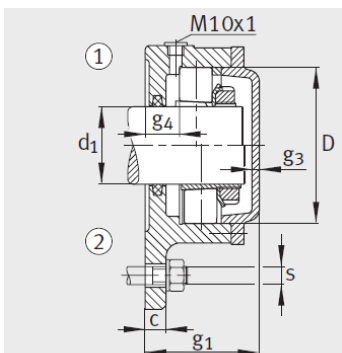

设计类型 A

- ① 定位轴承
- ② 浮动轴承

型号:

轴承座: F507-WA-L

轴承1: 2207-K-TVH-C3

轴承2: 22207-E1-K

紧定套: H307

止动环: FE72/2(1)

毛毡条 a × b × l / 件: 6 × 5 × 13
0 / 1

质量 m 轴承座 kg: 2

尺寸:

d: 30

a: 145

g: -

h: 130

c: 12

D: 72

g: 63

g: 5

g: 17

h: 48.5

m: 130

s(mm): M12

s(inch): 1/2

